



Installation and Operation Instructions HeatBloC® K31 DN 25 / DN 32



DN 25



DN 32

Table of Contents

1	General Information.....	3
1.1	Scope of these instructions.....	3
1.2	Designated use.....	3
2	Safety instructions.....	4
3	Product description.....	5
3.1	Equipment.....	5
3.2	Function.....	6
3.2.1	Check valve.....	7
4	Mounting and installation [specialist].....	8
4.1	Installation and commissioning of the HeatBloC®	8
4.2	Accessories: Cutting-ring compression fitting (not included in the scope of delivery).....	11
5	Scope of delivery [specialist].....	12
5.1	Spare parts DN 25.....	12
5.2	Spare parts DN 32.....	14
6	Technical data.....	16
6.1	Pressure drop and pump characteristic curves DN 25.....	17
6.2	Pressure drop and pump characteristic curves DN 32.....	17
7	Disposal.....	18

1 General Information



Carefully read these instructions before installation and commissioning.

Save these instructions in the vicinity of the installation for future reference.

1.1 Scope of these instructions

These instructions describe the installation, commissioning, functioning and the operation of an unmixed HeatBloC®.

For other components of the installation, such as the pump, the controller or the modular distribution manifold, please observe the instructions of the corresponding manufacturer. The chapters called [specialist] are intended for specialists only.

1.2 Designated use

The product may only be used in heating circuits taking into consideration the technical limit values indicated in these instructions.

It must **not** be used in drinking water applications.

Improper usage excludes any liability claims.

This product complies with the relevant directives and is therefore labelled with the CE mark.

The Declaration of Conformity is available upon request, please contact the manufacturer.

Only use PAW accessories with the product.

2 Safety instructions

The installation and commissioning as well as the connection of electrical components require technical knowledge commensurate with a recognised vocational qualification as a fitter for plumbing, heating and air conditioning technology, or a profession requiring a comparable level of knowledge [specialist].

The following must be observed during installation and commissioning:

- relevant local and national regulations
- accident prevention regulations of the professional association
- instructions and safety instructions mentioned in these instructions

CAUTION



Personal injury and damage to property!

The product must only be used in heating circuits filled with heating water according to VDI 2035 / Ö-Norm H 5195-1.

- ▶ The product must **not** be used in drinking water applications.

NOTICE

Material damage due to mineral oils!

Mineral oil products cause lasting damage to seals made of EPDM, whereby the sealant properties are lost. We do not assume liability nor provide warranty for damage to property resulting from sealants damaged in this way.

- ▶ It is imperative to prevent the EPDM sealing elements from making contact with substances containing mineral oils.
- ▶ Use a silicone- or polyalkylene-based lubricant free of mineral oil such as Unisilikon L250L and Syntheso Glep 1 from Klüber or a silicone spray.

3 Product description

The HeatBloC® is a preassembled group of fittings for heating circuits. The integrated pump can be isolated by means of the ball valves and maintenance work on the pump can thus be carried out without draining the heating circuit.

The PAW HeatBloC® is designed such that it can be directly mounted onto a PAW distribution manifold or a mounting plate. With transition connections, PAW HeatBloC®s can also be mounted on PAW modular distribution manifolds of other dimensions.

3.1 Equipment

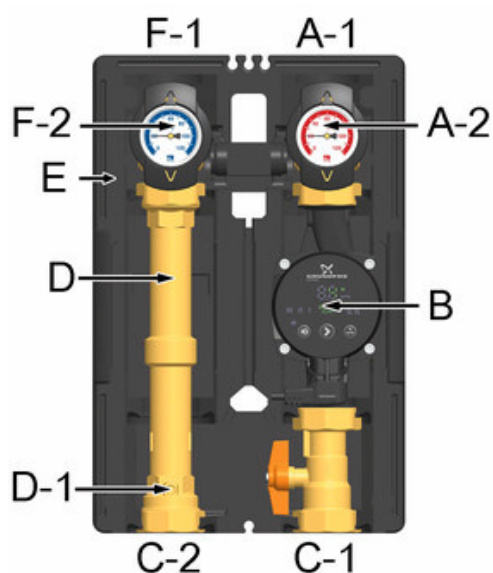

- A-1 Flow to the consumer circuit
- A-2 All-metal thermometer with immersion sleeve, integrated in the ball valve (flow)
- B Heating pump
- C-1 Flow from the heat generator
- C-2 Return to the heat generator
- D Return pipe
- D-1 Check valve, can be opened
- E Design insulation with optimised function
- F-1 Return from the consumer circuit
- F-2 All-metal thermometer with immersion sleeve, integrated in the ball valve (return)

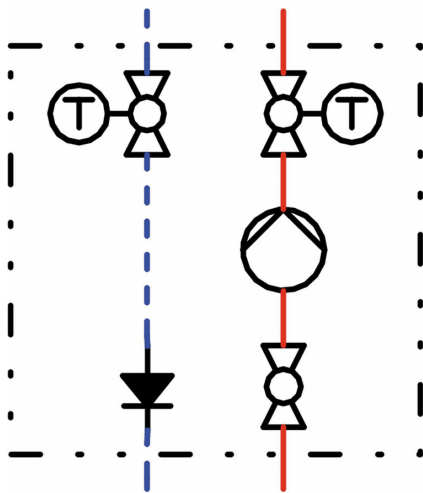
3.2 Function

Unmixed HeatBloC®

An integrated circulation pump transports the water from the heat generator to the consumers. The ball valves allow a maintenance of the pump, of the boiler / heat generator circuit as well as of the consumer circuit without putting the entire installation out of operation. Two thermometers display the temperatures of the flow and the return and allow thus a function control. The integrated check valve can be opened, it avoids an unwanted circulation and can be put out of operation to flush and fill the installation. The insulation avoids that heat energy gets lost.

Application range:

- Heating circuit systems for modulating temperature heating systems
- Heating circuit systems for storage tank charging and discharging

3 Product description

3.2.1 Check valve

The product is equipped with a check valve in the return pipe. The check valve can be opened.

Operation

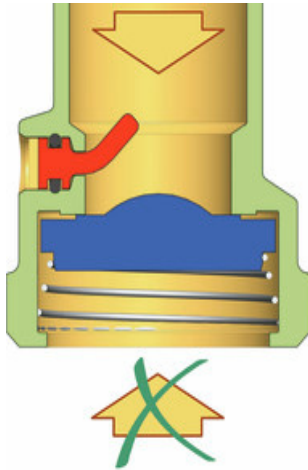

During operation, the marking must point to "Z".

- The check valve is closed.
- Flow only in the direction of the arrow.



Filling, draining, venting

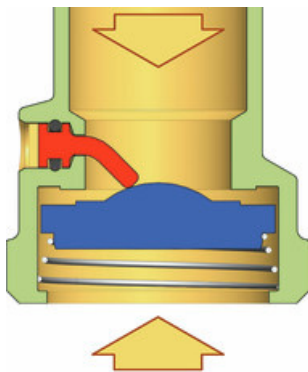

For filling, draining and venting the installation, the marking must point to "A".

- The check valve is open.
- Flow in both directions.



4 Mounting and installation [specialist]

The HeatBloC® can either be mounted on a distribution manifold or on a wall bracket. The distribution manifold and the wall bracket are optional accessories and are thus not included in the scope of delivery.

NOTICE

Damage to property!

The installation site must be dry, stable, frost-proof and protected against ultraviolet radiation in order to prevent material damage of the installation.

4.1 Installation and commissioning of the HeatBloC®

The HeatBloC® can be mounted

Option 1:

on a PAW modular distribution manifold.

Option 2:

on a mounting plate with transition thread connections.

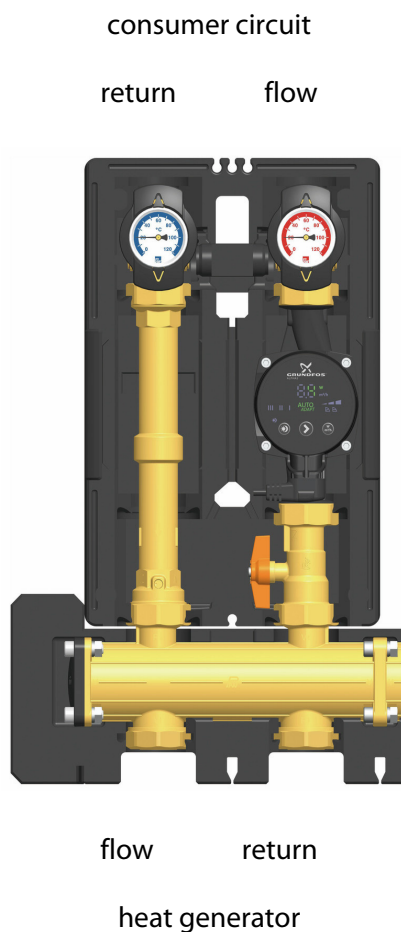

4 Mounting and installation [specialist]

Option 3:

directly on a wall bracket

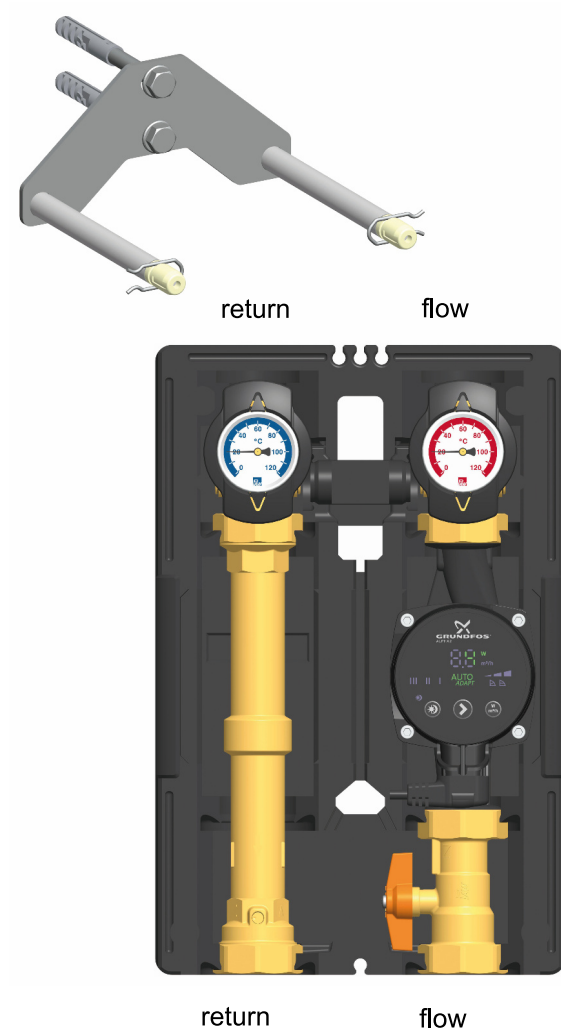

Please observe the separate and respectively corresponding instructions regarding the installation of the distribution manifold, of the mounting plate and of the wall bracket.

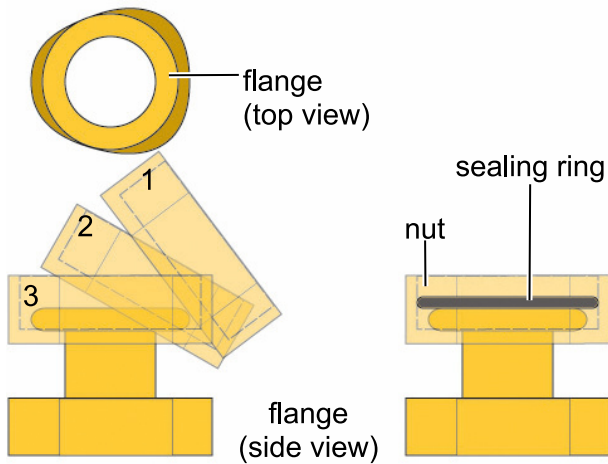

1. Take off the thermometer handles (A-2, F-2) and remove the insulating front shell of the HeatBloC®.
2. Remove the insulating piece above the return pipe (D).
3. Unscrew the nuts on the lower connections of the HeatBloC® and take out the sealing rings.

If a PAW modular distribution manifold or transition connection is used:

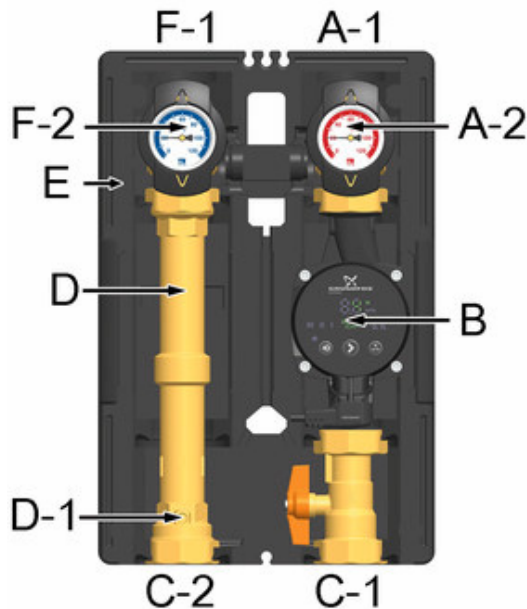

4. Put the two nuts over the flanges.
5. Insert the sealing rings into the nuts.
6. Put the HeatBloC® onto the two nuts.
7. Tighten the nuts. Make sure that the nuts do not get jammed and that the sealing rings do not slip.
8. Connect the HeatBloC® to the installation by using the pipes. The installation to the piping must be carried out without any tension.
9. Connect the pump.
10. Carry out a pressure test and check all thread connections.
11. Mount the insulating piece in front of the return pipe (D).
12. Mount the insulating front shell and the thermometer handles (A-2, F-2).

4 Mounting and installation [specialist]

4.2 Accessories: Cutting-ring compression fitting (not included in the scope of delivery)

The connection to the heating installation can be carried out fast, pressure-proof and without soldering if you use the optionally available compression fittings.

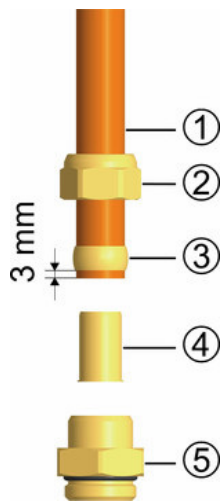

Not included in the scope of delivery!

1. Push the union nut ② and the cutting ring ③ onto the copper pipe ①. The pipe must protrude at least 3 mm from the cutting ring in order to ensure the force transmission and the sealing.
2. Insert the support sleeve ④ into the copper pipe.
3. Insert the copper pipe with the plugged-on individual parts ②, ③ and ④ as far as possible into the body of the compression fitting ⑤.
4. First, screw the union nut ② manually.
5. Tighten the union nut ② by rotating one full turn. Secure the body of the compression fitting ⑤ against distort in order to avoid damaging the sealing ring.

5 Scope of delivery [specialist]

NOTICE

Serial number

Complaints and requests/orders of spare parts will only be processed with information on the serial number! The serial number is placed on the return pipe of the product.

5.1 Spare parts DN 25

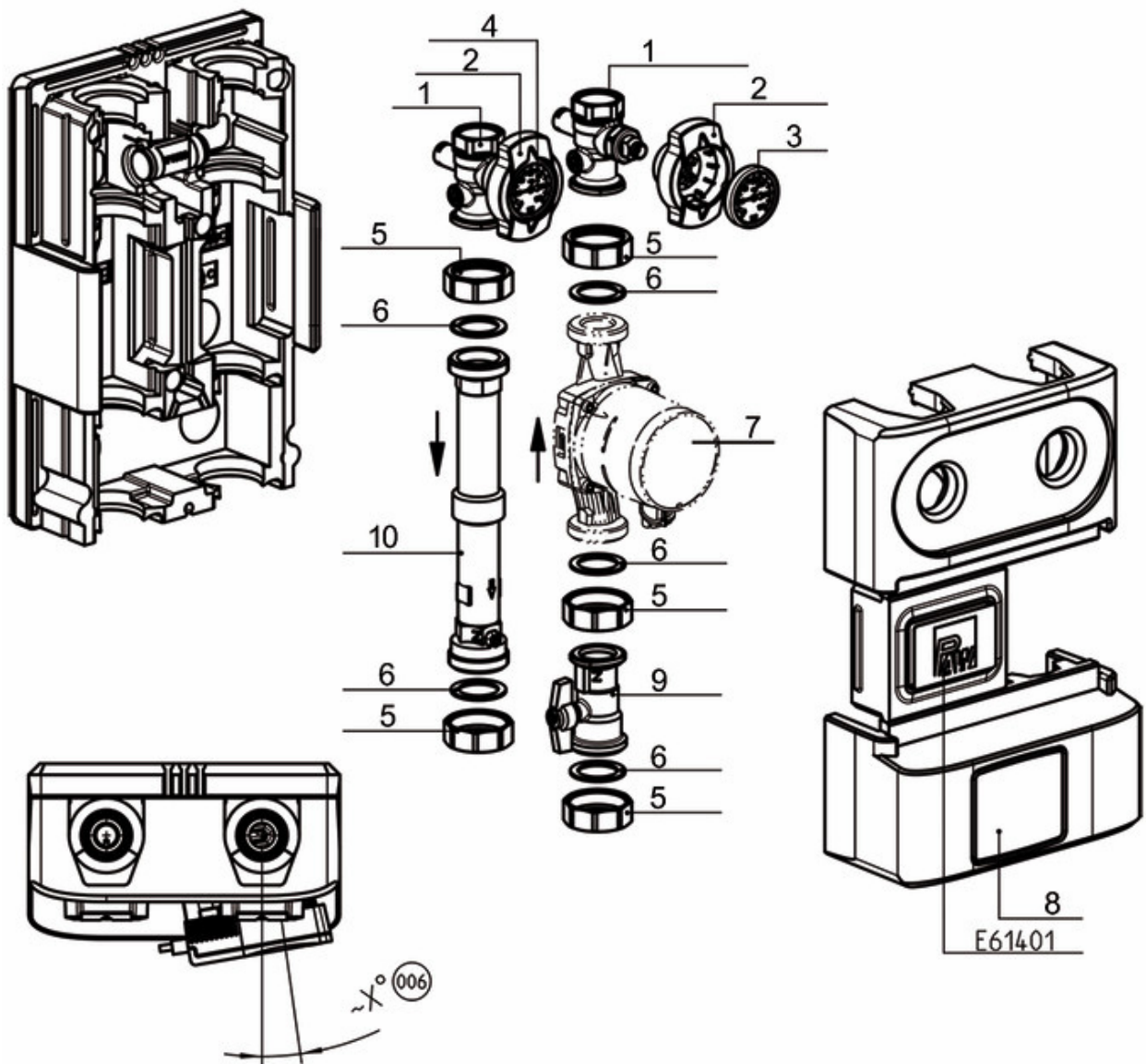

5 Scope of delivery [specialist]

Position	Spare part	Item number
1	Thermometer ball valve DN 25, flange 1" x 1" int. thread	N00244
2	Thermometer handle for thermometer ball valve 1"	N00248
3	Dial thermometer, red scale, d = 50 mm, 0-120 °C	N00242
4	Dial thermometer, blue scale, d = 50 mm, 0-120 °C	N00243
5	Union nut G 1½"	N00269
6	Gasket 1" for threaded connection 1½"	N00131
7	Pump see following table	
8	Insulation for HeatBloC® DN 25	N00016
9	Pump ball valve DN 25, flange 1" x 1½" ext. thread	2109
10	Brass pipe DN 25, 2 x 1½" ext. thread, 180 mm, with check valve	N00021

Item no. heating circuit	Pump	Item no. pump	EEl
36013WP6	Wilo Para SC 25/6-43	N00259	< 0.20
36013WP8	Wilo Para SC 25/8-60/O	N00271	< 0.20
36013WN06	Wilo Yonos PICO 25/1-6	N00214	< 0.20
36013GM6	Grundfos UPM3 Auto L 25-70 PP3	N00237	< 0.20
36013GH6	Grundfos Alpha2.1 25-60	N00236	< 0.17
36013GL9	Grundfos UPML 25-95 Auto	N00396	< 0.23

5.2 Spare parts DN 32

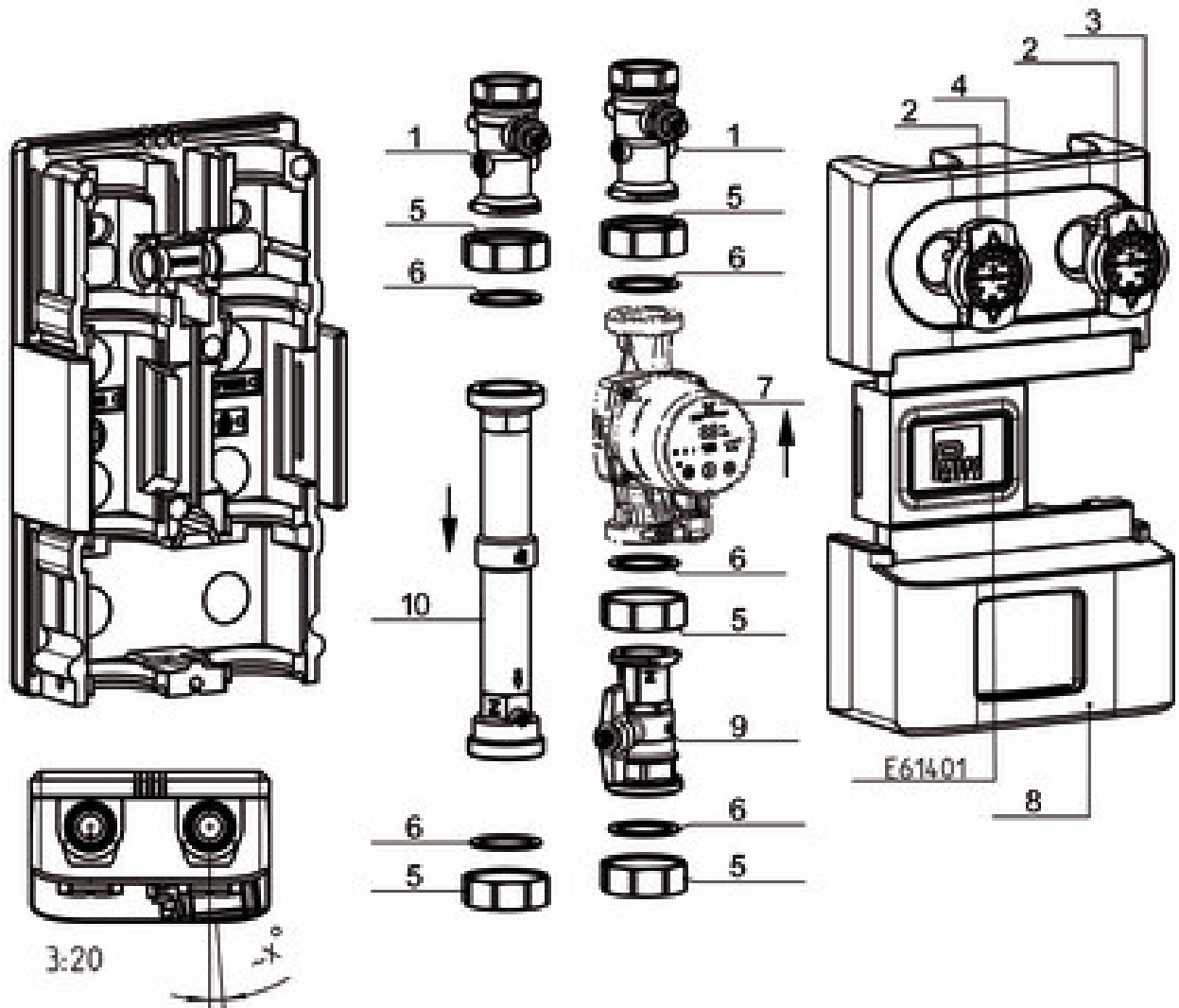

5 Scope of delivery [specialist]

Position	Spare part	Item number
1	Thermometer ball valve DN 32, flange 1¼" x 1¼" int. thread	N00245
2	Thermometer handle for thermometer ball valve 1"	N00248
3	Dial thermometer, red scale, d = 50 mm, 0-120 °C	N00242
4	Dial thermometer, blue scale, d = 50 mm, 0-120 °C	N00243
5	Union nut G 2"	N00270
6	Gasket 1¼", for threaded connection 2"	N00133
7	Pump see following table	
8	Insulation for HeatBloC® DN 32	N00027
9	Pump ball valve DN 32, 2" ext. thread x flange 1¼"	N00294
10	Brass pipe DN 32, 2x 2" ext. thread, 292 mm, with check valve	N00140

Item no. heating circuit	Pump	Item no. pump	EEl
39013WP6	Wilo Para SC 30/6-43	N00261	< 0.20
39013WN06	Wilo Yonos PICO 30/1-6	N00313	< 0.20
39013WY10	Wilo Yonos MAXO plus 30/0.5-10	N00398	< 0.20
39013GM6	Grundfos UPM3 Auto L 32-70 PP3	N00240	< 0.20
39013GH6	Grundfos Alpha2.1 32-60	N00239	< 0.17
39013GL9	Grundfos UPML 32-105 Auto	N00344	< 0.23

6 Technical data

HeatBloC® K31	DN 25 (1")	DN 32 (1¼")
Dimensions		
Centre distance (1)	125 mm	125 mm
Width insulation (2)	250 mm	250 mm
Height insulation (3)	383 mm	441 mm
Installation length (4)	340 mm	400 mm
Connections		
Outlet (A-1, F-1)	1" int. thread	1¼" int. thread
Inlet (C-1, C-2)	1½" ext. thread, flat sealing	2" ext. thread, flat sealing
Operating data		
Max. pressure	6 bars	6 bars
Max. temperature	95 °C	95 °C
K _{V5} value [m ³ /h]	7.2	15.1
Opening pressure check valve (D-1)	200 mm wc, can be opened	
Materials		
Valves and fittings	Brass	
Gaskets	EPDM	
Insulation	EPP	

6 Technical data

6.1 Pressure drop and pump characteristic curves DN 25

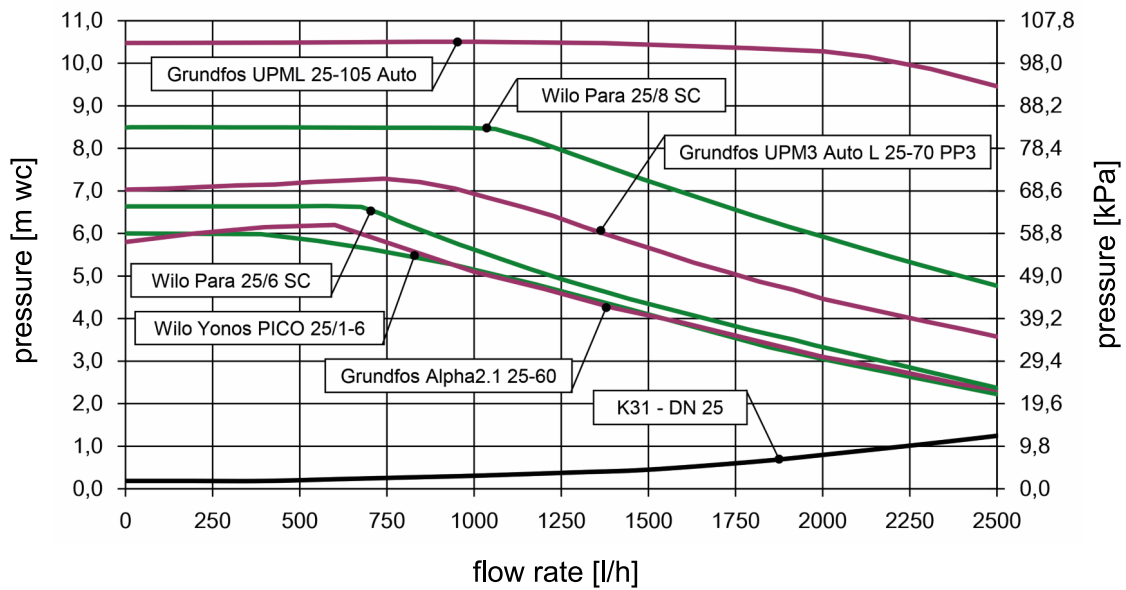

6.2 Pressure drop and pump characteristic curves DN 32

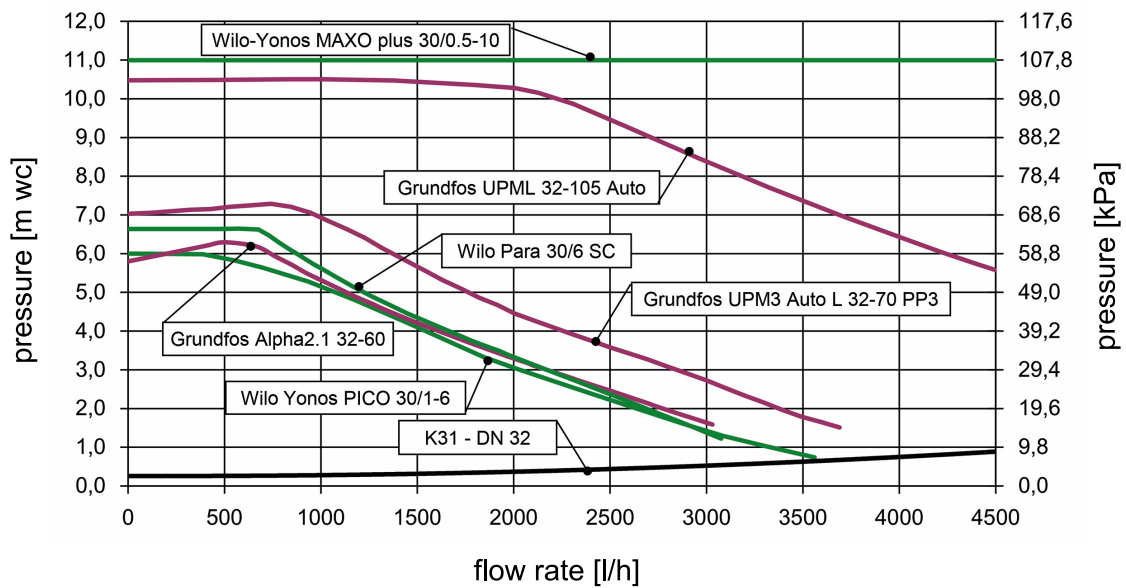

7 Disposal

NOTICE

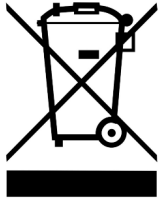

Electrical and electronic devices must not be disposed of in the household waste. For your return, there are free collection points for electrical appliances and, if necessary, additional points of acceptance for the reuse of the devices in your area. The addresses can be obtained from your city or communal administration.

If the old electrical or electronic device contains personal data, you are responsible for deleting it before returning the device.

Batteries and rechargeable batteries must be removed prior to the disposal of the product. Depending on the product equipment (partly with optional accessories), single components can also contain batteries and rechargeable batteries. Please observe the disposal symbols on the components.

NOTICE



Disposal of transport and packaging materials

The packaging materials are made of recyclable materials and can be disposed of with recyclable materials.



7 Disposal

Item no. 993x013x-mub-en

Translation of the original instructions

We reserve the right to make technical changes without notice!

Printed in Germany – Copyright by PAW GmbH & Co. KG

PAW GmbH & Co. KG

Böcklerstraße 11

31789 Hameln, Germany

www.paw.eu

Phone: +49-5151-9856-0

Fax: +49-5151-9856-98