



Installation and Operation Instructions Domestic Hot Water Module FriwaMega - DN 32

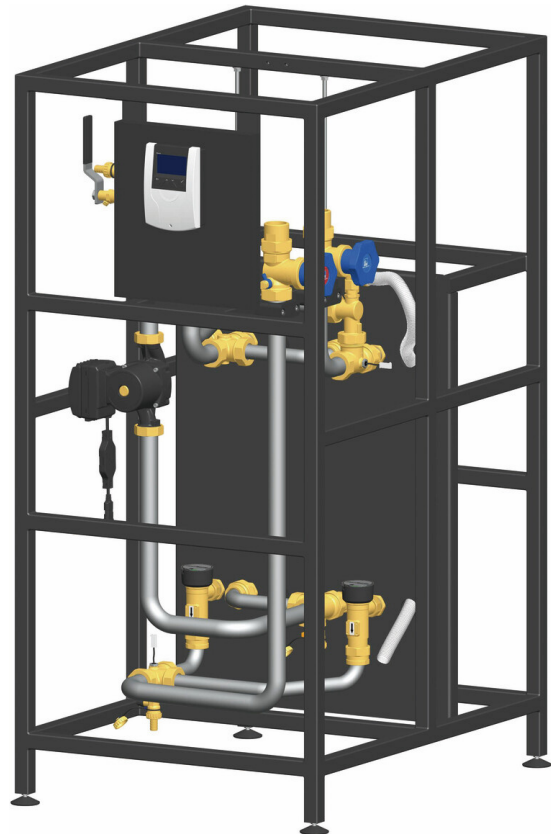

Table of Contents

1	General Information.....	3
1.1	Scope of these instructions.....	3
1.2	About this product.....	4
1.3	Designated use.....	5
2	Safety instructions.....	6
3	Product description.....	7
4	Dimensioning and planning.....	8
4.1	Dimensioning of the tank.....	10
4.2	Water quality requirements.....	11
5	Circulation mode.....	13
6	Mounting and installation [specialist].....	14
7	Commissioning [specialist].....	17
7.1	Filling the primary circuit.....	18
7.2	Commissioning of the controller.....	19
7.3	Adjustment of the temperature.....	20
7.4	Maximum withdrawal flow rate.....	21
8	Maintenance.....	24
8.1	Inspection.....	24
8.2	Maintenance.....	25
9	Scope of delivery [specialist].....	26
9.1	Spare parts controller and insulation.....	26
9.2	Spare parts primary circuit.....	27
9.3	Spare parts secondary circuit.....	28
10	Technical data.....	30
10.1	Pressure drop and pump characteristic curves.....	31
10.2	Dimensional drawing.....	32
11	Disposal.....	34
12	Commissioning report.....	35

1 General Information



Carefully read these instructions before installation and commissioning.

Save these instructions in the vicinity of the installation for future reference.

1.1 Scope of these instructions

These instructions describe the installation, commissioning, functioning and the operation of the domestic hot water module FriwaMega. The chapters called [specialist] are intended for specialists only.

For other components of the system, such as tanks, controllers and pumps, please observe the instructions of the corresponding manufacturer.

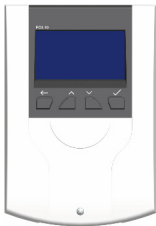
Station	Item number	Controller FC3.10	Primary pump	Circulation	Heat exchanger
FriwaMega	6407511		Grundfos UPMXL GEO 25-125	Optional: 6404135GH10	copper solder, 2 x 60 plates
	6407530				coated, 2 x 60 plates
FriwaMega with circulation	6407517		Grundfos UPMXL GEO 25-125	Grundfos UPML 25-105 N	copper solder, 2 x 60 plates
	6407535				coated, 2 x 60 plates

These articles are covered by Article 4(3) of the Pressure Equipment Directive 2014/68/EU and are designed and manufactured in accordance with good engineering practice.

The domestic hot water module complies with the relevant directives and is therefore labelled with the CE mark. The Declaration of Conformity is available upon request, please contact the manufacturer.

1.2 About this product

The FriwaMega is a domestic hot water module operating on the principle of a flow-type water heater.

The domestic hot water module is a premounted group of fittings checked for tightness and used to transfer the heat between the buffer tank and the domestic hot water circuit. It contains a preset controller and important valves and fittings and safety equipment to operate the unit:

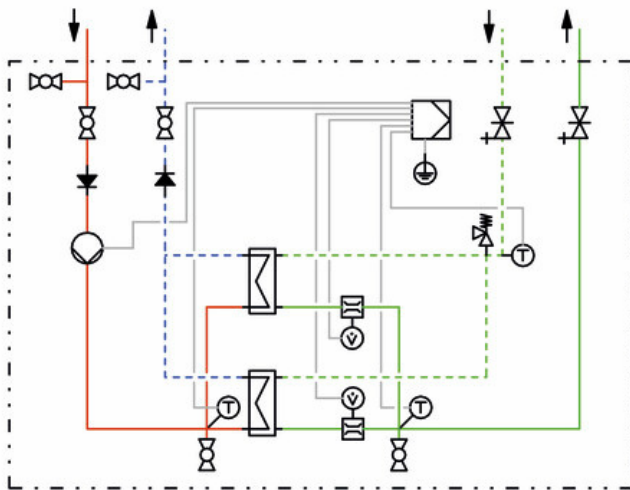

Domestic hot water module without circulation

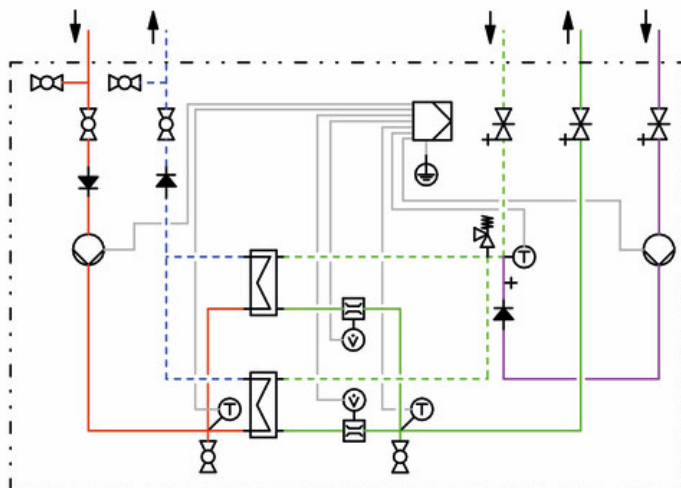

Domestic hot water module with circulation

- Premounted controller
- Ball valves in the primary circuit
- Temperature sensor at the domestic hot water outlet
- Temperature sensor at the cold water inlet
- Fill and drain valve to drain the heat exchangers in the primary and secondary circuit
- Safety valve in the secondary circuit
- Piston valves in the secondary circuit
- Flow rate sensor at the domestic hot water outlet
- Temperature sensor in the heating circuit flow line
- Vent valve, primary and secondary, to vent the heat exchangers



1 General Information

1.3 Designated use

The domestic hot water module must only be mounted in heating installations between the buffer tank and the domestic hot water circuit. Due to its design, the station must be mounted and operated in a vertical position! The technical limit values specified in these instructions must be observed.

Only use PAW accessories with the domestic hot water module. Improper usage excludes any liability claims.

Do not put the module into operation in case of any visible damage.

2 Safety instructions

The installation and commissioning as well as the connection of electrical components require technical knowledge commensurate with a recognised vocational qualification as a fitter for plumbing, heating and air conditioning technology, or a profession requiring a comparable level of knowledge [specialist].

The following must be observed during installation and commissioning:

- relevant local and national regulations
- accident prevention regulations of the professional association
- instructions and safety instructions mentioned in these instructions

CAUTION



Risk of burns!

Valves, fittings and pump may heat up to more than 95 °C during operation.

- ▶ The insulating shell must remain closed during operation.

WARNING

Malfunction!

- ▶ The station must be integrated in the potential equalisation of the electric installation. This can be guaranteed by establishing a potential equalisation connection to the main potential connection according to regulations or by the connected pipe system.

NOTICE

Material damage due to mineral oils!

Mineral oil products cause lasting damage to seals made of EPDM, whereby the sealant properties are lost. We do not assume liability nor provide warranty for damage to property resulting from sealants damaged in this way.

- ▶ It is imperative to prevent the EPDM sealing elements from making contact with substances containing mineral oils.
- ▶ Use a silicone- or polyalkylene-based lubricant free of mineral oil such as Unisilikon L250L and Syntheso Glep 1 from Klüber or a silicone spray.

3 Product description

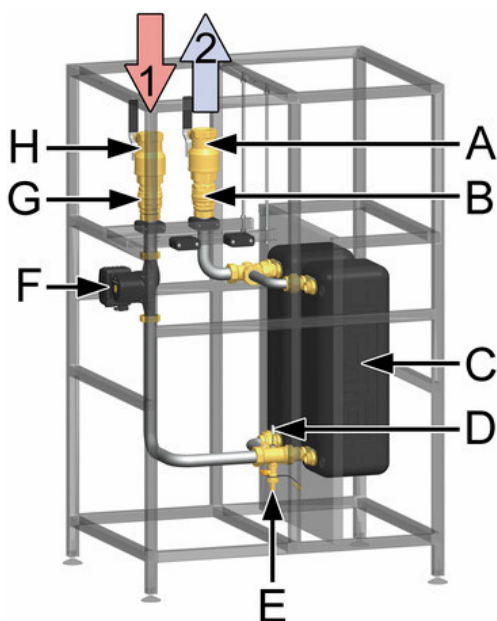

Connections primary circuit

- 1 Flow from the buffer tank (hot)
- 2 Return to the buffer tank (cold)

Equipment primary circuit

- A Return ball valve
- B Check valve
- C Heat exchanger
- D Temperature sensor Pt1000
- E Fill and drain valve
- F Primary pump
- G Check valve
- H Flow ball valve

Connections secondary circuit

- 3 Cold water inlet
- 4 Hot water outlet
- 5 Hot water circulation

Equipment secondary circuit

- a Piston valve hot water circulation
- b Piston valve cold water inlet
- c Safety valve 10 bars, suitable for domestic water

Only for the protection of the station. Does not replace the pressure relief valve that has to be mounted on site!

- d Temperature sensor Pt1000
- e Heat exchanger
- f + g FlowSonic 1-130 l/min
- h Fill and drain valve
- i Temperature sensor Pt1000
- j Circulation pump
- k Piston valve hot water outlet

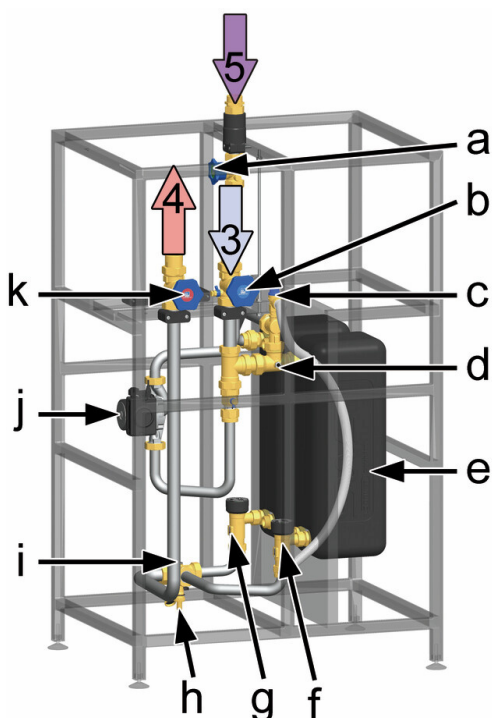

4 Dimensioning and planning

The DHW module will only work flawlessly if the installation meets certain requirements. Please take some time to plan the assembly.

WARNING



Danger of scalding due to hot water!

Undesirable circulation of water in the primary circuit can cause the exit of water of up to 90 °C at the withdrawal point.

- ▶ External pumps must not be installed between the domestic hot water module and the buffer tank.
- ▶ The domestic hot water module must not be connected to a distribution manifold of a heating circuit.

Mounting example:

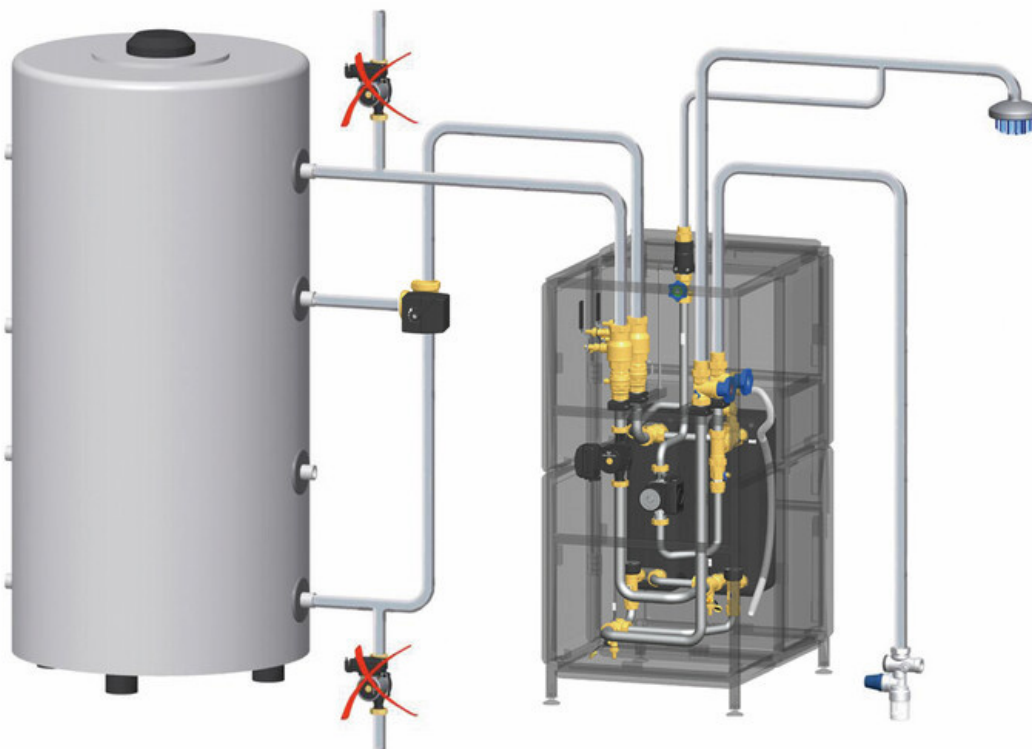

FriwaMega with optional circulation set (additionally required, item no. 6404135GH10) as well as safety group according to DIN 1988 (additionally required).

NOTICE**Use of trace heating tapes**

Installations without a circulation line with an increased pipe content can cause a considerable drop of temperature in the pipes during longer withdrawal breaks. This leads to a delayed start behaviour of the domestic hot water module, which slows down the regulation of the set nominal temperature.

This effect can be reinforced when using electrical trace heating systems in combination with short withdrawals. There is a risk that different temperature ranges will develop in the domestic hot water line due to the delayed start behaviour. This can lead to initially fluctuating outlet temperatures during subsequent longer withdrawals.

Therefore, we do not recommend an electric trace heating system. If an installation is unavoidable, the following steps are recommended:

- ▶ If there is a long pipe section between the buffer storage tank and the domestic hot water module, the comfort function should be activated (increased tendency to calcification). We recommend the shortest possible installation routes between the buffer tank and the DHW module.
- ▶ Avoid short withdrawals.
- ▶ Instead of an over-dimensioned domestic hot water module, we recommend cascading several smaller modules.

Optimal operation of the station

In order to guarantee an optimal control, no additional hydraulic pressure losses should occur on the primary side (e.g. due to the installation of a mud strainer, a strainer or a mixing valve).

4.1 Dimensioning of the tank

The following table helps you to calculate the approximately required volume of the buffer tank.

Temperature in the buffer tank	Domestic hot water temperature set at the controller	Required tank volume per litre of hot water
50 °C	45 °C	1.2 litres
60 °C*	45 °C	0.8 litre
	50 °C	1.0 litre
	55 °C	1.3 litre
70 °C	45 °C	0.6 litre
	50 °C	0.7 litre
	55 °C	0.9 litre
80 °C	45 °C	0.5 litre
	50 °C	0.6 litre
	55 °C	0.7 litre

Calculation example for the dimensioning of the buffer tank:

Temperature in the buffer tank: 60 °C

Required withdrawal flow rate at the tap: 20 l/min

Domestic hot water temperature set at the controller: about 45 °C

How large must be the tank to allow a continuous withdrawal during 20 minutes without post-heating?

$$20 \text{ l/min} \times 20 \text{ min} = 400 \text{ l}$$

$$400 \text{ l} \times 0.8 = 320 \text{ l}$$

The heated part of the buffer tank must have a volume of 320 litres.

4 Dimensioning and planning

4.2 Water quality requirements

The domestic hot water modules constructively decrease the precipitation of chalk in the heat exchanger. For installations with an elevated total hardness of the potable water and/or high temperatures, a water treatment is recommended. Depending on the chemical composition of the water at the installation site, the selection and adequacy of the plate heat exchanger has to be checked. Please observe the following table:

Influence of the water quality on the corrosion resistance for domestic hot water applications

Water content	Concentration (mg/l or ppm)	Time limits	Heat exchanger with copper solder	Heat exchanger with Sealix® sealing
Alkalinity (HCO ₃ ⁻)	< 70	within 24 hours	0	+
	70-300		+	+
	> 300		0/+	+
Sulphate (SO ₄ ²⁻)	< 70	no limit	+	+
	70-300		0/-	+
	> 300		-	+
HCO ₃ ⁻ / SO ₄ ²⁻	> 1.0	no limit	+	+
	< 1.0		0/-	+
Electrical conductivity	< 10 µS/cm	no limit	0	+
	10-500 µS/cm		+	+
	> 500 µS/cm		0	+
pH value	< 6.0	within 24 hours	0	+
	6.0-7.5		0	+
	7.5-9.0		+	+
	9.0-10		0	0
	> 10.0		0	-
Ammonium (NH ₄ ⁺)	< 2	within 24 hours	+	+
	2-20		0	+
	> 20		-	-
Chloride (Cl ⁻)	< 100	no limit	+	+
	100-200		+	+
	200-300		+	+
	> 300		0/+	0

Water content	Concentration (mg/l or ppm)	Time limits	Heat exchanger with copper solder	Heat exchanger with Sealix® sealing
Free chlorine (Cl ₂)	< 1	within 5 hours	+	+
	1-5		0	0
	> 5		0/-	0
Hydrogen sulphide (H ₂ S)	< 0.05	no limit	+	+
	> 0.05		0/-	0
Free (aggressive) carbon dioxide (CO ₂)	< 5	no limit	+	+
	5-20		0	+
	> 20		-	+
Total hardness (°dH)	4.0-8.5	no limit	+	+
Nitrate (NO ₃ ⁻)	< 100	no limit	+	+
	> 100		0	+
Iron (Fe)	< 0.2	no limit	+	+
	> 0.2		0	+
Aluminium (Al)	< 0.2	no limit	+	+
	> 0.2		0	+
Manganese (Mn)	< 0.1	no limit	+	+
	> 0.1		0	+

- + Good resistance under normal conditions
- 0 Corrosion may occur, especially if further factors are evaluated with 0
- Use is not recommended

5 Circulation mode

The domestic hot water module is optionally equipped with a circulation pump. Modules without circulation can be subsequently equipped with a circulation set for an internal retrofitting.

For the operation of the circulation pump, three possible operation modes are stored in the controller (see controller instructions, chapter *Circulation*).

- **Pulse-controlled operation** (depending on the demand / requirements):

The short actuation of a hot water tap (tap pulse: less than 5 sec.) starts the circulation pump. The circulation pump will then run for several minutes (adjustable).

- **Time-dependent operation:**

The operation of the circulation pump can be set on a week clock within freely selectable periods of time. In this operation mode, the circulation is activated at the beginning of the period of the time chosen. The circulation will stop after the end of the chosen period of time.

- **Temperature-dependent operation:**

In this operation mode, the circulation is only activated if the adjustable minimum temperature at the circulation temperature sensor is not reached. The circulation stops after the adjustable switch-off temperature has been reached.

The operating modes can be combined with each other as wished, e.g. the time- and the temperature-dependent operating modes. The circulation is only activated if the temperature at the circulation temperature sensor falls below the required value and if the time window is active.

If the pulse-controlled operation mode is additionally activated, the circulation pump runs continuously during the time slot and can be activated by a tap pulse outside the time slot. The circulation prematurely stops if the adjusted switch-off temperature is exceeded.

NOTICE

Damage to property!

When the DHW module is delivered, the circulation is not activated (see controller instructions, chapter *Circulation*). It is mandatory to select and preset the operation mode. The revolution speed of the circulation pump is defined via the PWM signal (factory setting: 40%).

6 Mounting and installation [specialist]

The domestic hot water module must only be connected with the storage tank by separate connections for the flow and return. External pumps must not be installed between the domestic hot water module and the buffer tank. The circulation of water causes considerable temperature fluctuations.

The DHW connection must be carried out in accordance with the relevant norms (e.g. DIN 1988)!

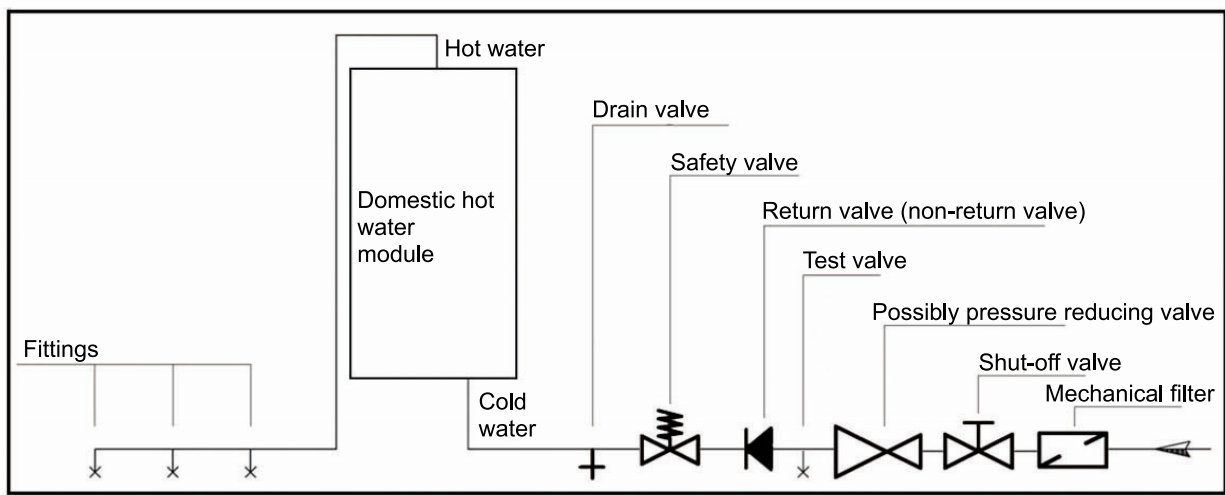

NOTICE

Damage to property!

The pressure relief valve integrated in the station does not replace the safety groups of the potable water connection as per DIN 1988. The pressure relief valve only protects the module from overpressures in case of servicing.

NOTICE

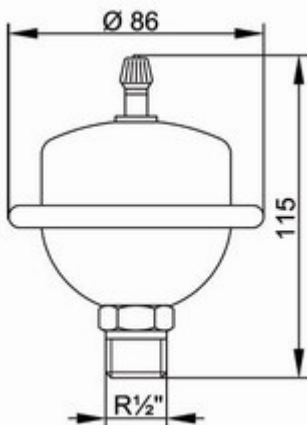

Damage to property!

If there are water supplies that may cause pressure surges (for example flush valves, washing machines or dishwashers) connected to the same mains as the station, we recommend the installation of water hammer arresters close to the place where these pressure surges may be caused.

⚠ WARNING

Risk to life and limb due to electric shock!

- ▶ Prior to commencing electrical work on the controller, pull the mains plug!
- ▶ Only after completing all work, plug the mains plug into a socket. This avoids an unintentional start of the motors.

NOTICE
Damage to property!

The installation site must be dry, stable, frost-proof and protected against ultraviolet radiation in order to prevent material damage of the installation.

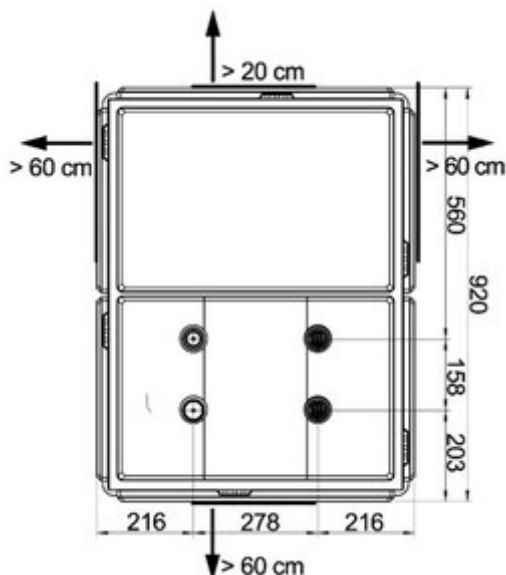

1. Determine the mounting location of the domestic hot water module near the buffer tank.
In long pipes, the transmission performance may be reduced due to higher pressure losses in the primary circuit.
2. Remove the packaging of the station.
3. Remove the station from the pallet and position it at the location of installation.
4. Mount the enclosed stand feet to compensate the unevenness of the floor.

5. The station can be mounted against the wall. If you want to remove the insulation, a free space of about 20 cm must be left to the wall (see figure).
6. For the operation of the hydraulics and a subsequent servicing, you have to leave a space of at least 60 cm to the front (controller) and to one side (see figure).
7. Pipe the fresh water station with the installation according to the illustration below. When the station is delivered, the ball valves and piston valves are closed, in order to protect the station against dirt.

The domestic hot water side is additionally closed with caps in order to avoid impurities.

Before connecting the pipes, make sure that the connections are free from dirt.

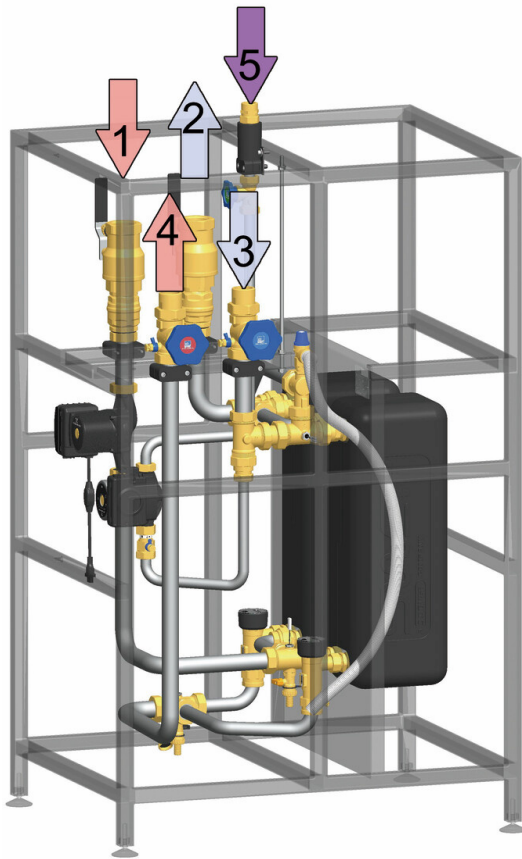

- 1 **Primary side: Flow from the buffer tank**
 Connection: 1½" int. thread, flat sealing; piping:
 at least DN 40, 42 x 1.5 mm, max. length 4 m
 Make sure to vent the station at the highest point!
- 2 **Primary side: Return to the buffer tank**
 Connection: 1½" int. thread, flat sealing; piping:
 at least DN 40, 42 x 1.5 mm, max. length 4 m
 Make sure to vent the station at the highest point!
- 3 **Secondary side: Cold water inlet**
 Connection: 1¾" ext. thread, flat sealing
- 4 **Secondary side: Domestic hot water outlet**
 Connection: 1¾" ext. thread, flat sealing
- 5 **Secondary side:**
 Hot water circulation, return
 Connection: 1¼" ext. thread, flat sealing

7 Commissioning [specialist]

NOTICE

Open the valves in the pipes and in the module **slowly** in order to prevent pressure surges.

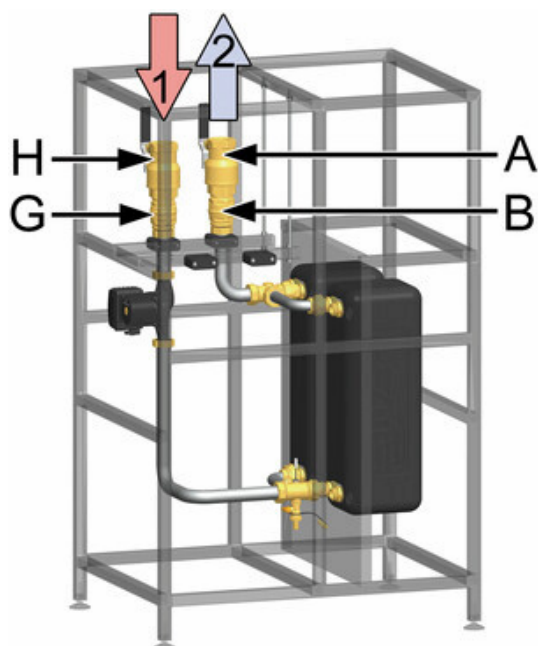

Function of the check valve

The ball valves (A) and (H) in the primary circuit are equipped with check valves (B) and (G), in order to avoid unwanted gravity circulation.

To vent and flush the installation, the check valves must be open. Turn the opening mechanism of the check valves into position **180°**. The check valve is not operating.

For the operation of the installation, all (ball) valves must be completely open and the check valves must be closed again (position **0°**).

Check valve (normal flow direction in the figure: downwards)

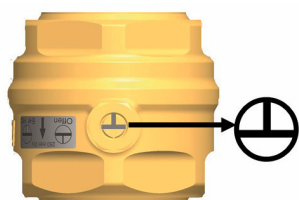

Position 0 ("operation")

Check valve is operating,
flow only in flow direction.

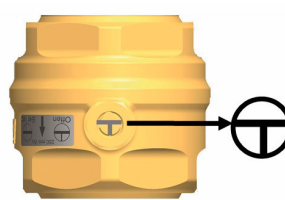

Position 180° ("open")

Check valve not operating,
flow in both directions.

7.1 Filling the primary circuit

WARNING



Danger of scalding due to hot water!

The system is under pressure. By opening the safety / vent valve, hot water with a temperature of up to 90 °C may exit and cause personal injury.

- ▶ Open each valve slowly and with sufficient distance.

If the storage tank is (partly) filled

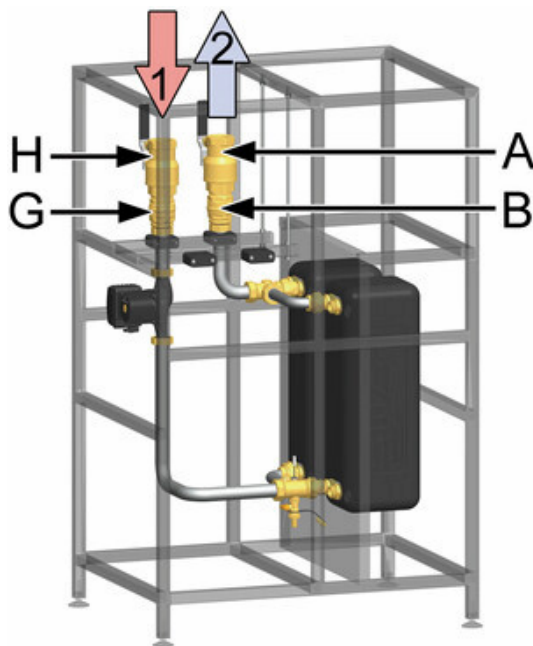

1. Slowly open the ball valves (A) and (H).
2. Open the check valves (B) and (G) at the opening mechanism (**180°**, see chapter Commissioning).
3. Fill the storage tank using fill valves available on site until an operating pressure of about 1.5 bar* is reached.

Use heating water compliant with the standards VDI 2035 / ÖNorm H5195-1.

4. Vent the pipe system at the designated points on site.
5. Check the operating pressure of the storage tank after the venting and increase the pressure if necessary.
6. Put the check valves (B) and (G) into operating position (**0°**, see chapter Commissioning).

Primary circuit

* 1.5 bar in the primary circuit = recommended minimum value

The pressure also depends on the individual system pressures and on the components of the heating installation!

7.2 Commissioning of the controller

WARNING



Risk to life and limb due to electric shock!

- ▶ Check whether the sensors and pumps have been connected to the controller and the controller housing is closed. Only under these circumstances, the mains plug of the controller can be plugged into a socket.



1. Make sure that the integration of the fresh water station in the potential equalisation of the installation is correct.
2. Connect the domestic hot water module to the mains (230 V, 50 Hz).
3. Carry out the commissioning of the controller (see controller instructions, chapter *Commissioning*).

After that, start the pump in the manual mode (= 100 %), see controller instructions, chapter *Automatic/manual mode*.

4. Let the pump run for several minutes to deaerate the domestic hot water module.
5. If the air noises have stopped, the primary pump can be switched off. To do so, in the menu "Automatic/manual mode", set the pump to "Automatic".

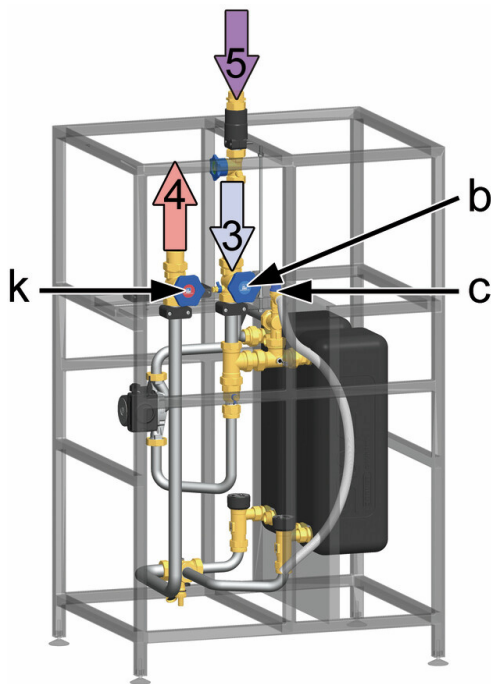

Secondary circuit

6. Slowly open the piston valves (b) and (k) on the secondary side.
7. Open at least one withdrawal point for domestic hot water (for example a tap) with a flow rate of at least 10 l/min and let the water run for about 2 minutes to vent the secondary circuit.
Close all withdrawal points of the secondary circuit afterwards.
8. Actuate the pressure relief valve (c) to vent the heat exchanger.
9. Check the module for tightness and make sure that the electronic components stay dry.
10. Set the desired domestic hot water temperature at the controller (see chapter *Nominal temperature*).
11. The domestic hot water module is now ready for operation.

7.3 Adjustment of the temperature

Set the desired (maximal) domestic hot water temperature at the controller at **"Main menu / Hot water / Nominal temperature"** (see controller instructions, chapter *Hot water*).

WARNING



Danger of scalding due to hot water!

In order to avoid scalding at the tap, the maximum domestic hot water temperature must not exceed **60 °C**.

Recommendation for comfort optimisation: For high buffer tank temperatures (e.g. solar thermal system), the hot water temperature must be set as high as possible (max. 60 °C).

Primary side

The required temperature on the primary side in the buffer tank depends on the desired domestic hot water temperature and on the required tap quantity. The temperature in the buffer tank must be at least 5 K above the desired domestic hot water temperature.

Secondary side:

The possible withdrawal flow rate [l/min] at the tap depends on the domestic hot water temperature adjusted at the controller and on the temperature available in the buffer tank.

Due to the system, considerable modifications of the domestic water flow rate cause fluctuations of the hot water outlet temperature. These fluctuations are usually compensated by the piping network in the building or by adding cold water at the fittings.

The recommended maximum domestic hot water flow rate through the domestic hot water module is ~130 l/min.

7 Commissioning [specialist]

7.4 Maximum withdrawal flow rate

Buffer tank temperature	Nominal temperature	max. output capacity*	Transmission performance	req. V _{Storage tank} per litre of HW	for an inlet temperature of 10 °C (cold water temperature) - max. withdrawal quantity** at the mixing valve at				Return temperature
					40 °C	45 °C	50 °C	55 °C	
45 °C	40 °C	85 l/min	178 kW	1.2 l	-	-	-	-	19 °C
50 °C	40 °C	110 l/min	230 kW	0.9 l	-	-	-	-	17 °C
	45 °C	82 l/min	199 kW	1.2 l	95 l/min	-	-	-	21 °C
55 °C	40 °C	130 l/min***	272 kW	0.8 l	-	-	-	-	15 °C
	45 °C	104 l/min	254 kW	1.0 l	121 l/min	-	-	-	18 °C
	50 °C	79 l/min	220 kW	1.3 l	105 l/min	89 l/min	-	-	23 °C
60 °C	40 °C	130 l/min***	272 kW	0.7 l	-	-	-	-	14 °C
	45 °C	123 l/min	300 kW	0.8 l	143 l/min	-	-	-	16 °C
	50 °C	100 l/min	278 kW	1.0 l	132 l/min	113 l/min	-	-	19 °C
	55 °C	77 l/min	241 kW	1.3 l	115 l/min		86 l/min	-	25 °C
65 °C	40 °C	130 l/min***	272 kW	0.6 l	-	-	-	-	13 °C
	45 °C	130 l/min***	317 kW	0.7 l	151 l/min	-	-	-	15 °C
	50 °C	117 l/min	325 kW	0.9 l	155 l/min	132 l/min	-	-	17 °C
	55 °C	96 l/min	301 kW	1.0 l	143 l/min	123 l/min	107 l/min	-	21 °C
	60 °C	75 l/min	261 kW	1.3 l	124 l/min	106 l/min	93 l/min	83 l/min	27 °C
70 °C	40 °C	130 l/min***	272 kW	0.5 l	-	-	-	-	13 °C
	45 °C	130 l/min***	317 kW	0.6 l	151 l/min	-	-	-	14 °C
	50 °C	130 l/min***	363 kW	0.7 l	173 l/min	148 l/min	-	-	16 °C
	55 °C	112 l/min	350 kW	0.9 l	167 l/min	143 l/min	125 l/min	-	19 °C
	60 °C	93 l/min	324 kW	1.1 l	154 l/min	132 l/min	115 l/min	103 l/min	22 °C
75 °C	40 °C	130 l/min***	272 kW	0.5 l	-	-	-	-	12 °C
	45 °C	130 l/min***	317 kW	0.6 l	151 l/min	-	-	-	14 °C
	50 °C	130 l/min***	363 kW	0.7 l	173 l/min	148 l/min	-	-	15 °C
	55 °C	125 l/min	394 kW	0.8 l	188 l/min	160 l/min	140 l/min	-	17 °C
	60 °C	107 l/min	375 kW	0.9 l	179 l/min	153 l/min	133 l/min	119 l/min	20 °C

Buffer tank temperature	Nominal temperature	max. output capacity*	Transmission performance	req. V _{Storage tank} per litre of HW	for an inlet temperature of 10 °C (cold water temperature) - max. withdrawal quantity** at the mixing valve at				Return temperature
					40 °C	45 °C	50 °C	55 °C	
80 °C	40 °C	130 l/min***	272 kW	0.4 l	-	-	-	-	12 °C
	45 °C	130 l/min***	317 kW	0.5 l	151 l/min	-	-	-	13 °C
	50 °C	130 l/min***	363 kW	0.6 l	173 l/min	148 l/min	-	-	14 °C
	55 °C	130 l/min***	408 kW	0.7 l	195 l/min	166 l/min	145 l/min	-	16 °C
	60 °C	120 l/min	419 kW	0.8 l	200 l/min	171 l/min	149 l/min	133 l/min	18 °C
85 °C	40 °C	130 l/min***	272 kW	0.4 l	-	-	-	-	12 °C
	45 °C	130 l/min***	317 kW	0.5 l	151 l/min	-	-	-	13 °C
	50 °C	130 l/min***	363 kW	0.6 l	173 l/min	148 l/min	-	-	14 °C
	55 °C	130 l/min***	408 kW	0.6 l	195 l/min	166 l/min	145 l/min	-	15 °C
	60 °C	130 l/min***	453 kW	0.7 l	216 l/min	185 l/min	162 l/min	144 l/min	17 °C
90 °C	40 °C	130 l/min***	272 kW	0.4 l	-	-	-	-	12 °C
	45 °C	130 l/min***	317 kW	0.4 l	151 l/min	-	-	-	12 °C
	50 °C	130 l/min***	363 kW	0.5 l	173 l/min	148 l/min	-	-	13 °C
	55 °C	130 l/min***	408 kW	0.6 l	195 l/min	166 l/min	145 l/min	-	14 °C
	60 °C	130 l/min***	453 kW	0.7 l	216 l/min	185 l/min	162 l/min	144 l/min	16 °C
95 °C	40 °C	130 l/min***	272 kW	0.4 l	-	-	-	-	11 °C
	45 °C	130 l/min***	317 kW	0.4 l	151 l/min	-	-	-	12 °C
	50 °C	130 l/min***	363 kW	0.5 l	173 l/min	148 l/min	-	-	13 °C
	55 °C	130 l/min***	408 kW	0.6 l	195 l/min	166 l/min	145 l/min	-	14 °C
	60 °C	130 l/min***	453 kW	0.6 l	216 l/min	185 l/min	162 l/min	144 l/min	15 °C

* The max. output capacity depends on the pressure drop on the primary side.

** The max. withdrawal quantity at the mixing valve depends on the length and the insulation of the pipes.

*** Max. flow rate: 130 l/min, with pressure drop of the Friwa of 1000 bar (for hydraulic reasons, higher values are only partly possible, measuring limit of the flow rate sensor ~133 l/min)

How to read the table (example):

The temp. in the heating storage tank (primary) is 65 °C and the nominal hot water temperature set at the controller is 50 °C (secondary):

- With a storage temp. of 65 °C, a max. of 117 l of domestic water per minute can be heated to 50 °C.
- This withdrawal corresponds to a performance of 325 kW.
- In order to obtain 1 l (or 100 l) of hot water with a temp. of 50 °C, the heating buffer tank must contain 0.9 l (or 90 l) with a temp. of 65 °C.
- These 117 l of hot water per minute with 50 °C can be mixed with cold water (10 °C) at the tap (mixing valve) to obtain 132 l per minute with 45 °C.
- The primary return temp. for a withdrawal of 117 l of domestic hot water/minute is 17 °C.

8 Maintenance

PAW stations are low in maintenance. Nevertheless, the following work needs to be carried out at regular intervals. For this, we recommend concluding a maintenance agreement with PAW GmbH & Co. KG.

NOTICE

Hygiene recommendation

At temperatures below 60 °C, legionella bacteria can occur. After a longer downtime such as holidays, it is recommended to thoroughly flush all pipes for some minutes.

8.1 Inspection

The following table provides recommendations for the frequency of inspection activities.

Component	Check	Interval
Pipes	<ul style="list-style-type: none"> ● Visual inspection for leaks, corrosion and other damaging effects ● Check of the insulation ● For removable sections: check for stone formation or corrosion from the inside 	Annually
Heat exchanger (tightness of the partition walls)	<ul style="list-style-type: none"> ● Control of the system pressure on the primary side 	Semi-annually
Heat exchanger (stone formation)	<ul style="list-style-type: none"> ● Comparison of the set with the real hot water temperature 	Semi-annually
Noise generation	<ul style="list-style-type: none"> ● Check the station for critical noises during the tapping process, e.g. trapped air 	Semi-annually
Temperature / flow rate sensors	<ul style="list-style-type: none"> ● Comparison of the information on the display and plausibility check 	Semi-annually
Electronic components and plug connections	<ul style="list-style-type: none"> ● Check if the cable plug connections of all components are firmly in place and intact 	Semi-annually

8 Maintenance

8.2 Maintenance

The following table provides recommendations for the frequency of maintenance activities.

Component	Check	Interval
Pressure relief valve	<ul style="list-style-type: none"> • Check for leaks by manual actuation • Actuation of the venting device to ensure that the valve is not stuck or calcified • Check whether the valve closes automatically after actuation and the water drains off completely 	Semi-annually
Shut-off valves	<ul style="list-style-type: none"> • Check for mobility by opening and closing 	Annually
Return stratification valve	<ul style="list-style-type: none"> • Check the functionality by manually activating the relay in the menu "Automatic/manual mode" 	Semi-annually

Clean the station with a damp cloth without any detergent.

WARNING



Risk to life and limb due to hot fluids!

Depending on the conditions, temperatures of up to 95 °C can develop in the product and escape. There is a risk of burns!

- ▶ For all service, maintenance or repair work, make sure that you are equipped with the necessary protective equipment (gloves / goggles).
- ▶ Before service, maintenance or repair work, take the product out of service and let it cool down.

9 Scope of delivery [specialist]

NOTICE

Serial number

Complaints and requests/orders of spare parts will only be processed with information on the serial number!

The serial number is placed on the support sheet of the station.

9.1 Spare parts controller and insulation

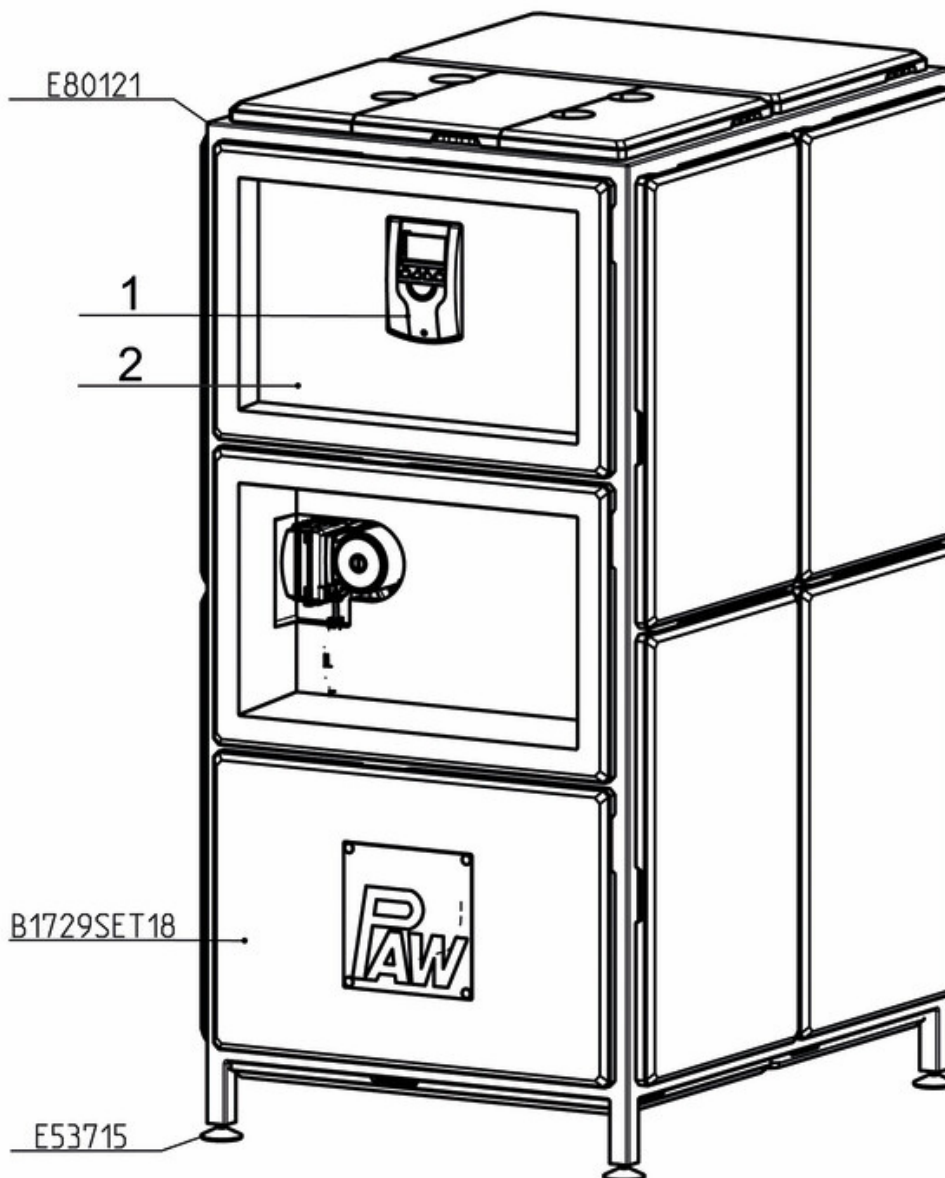

9 Scope of delivery [specialist]

9.2 Spare parts primary circuit

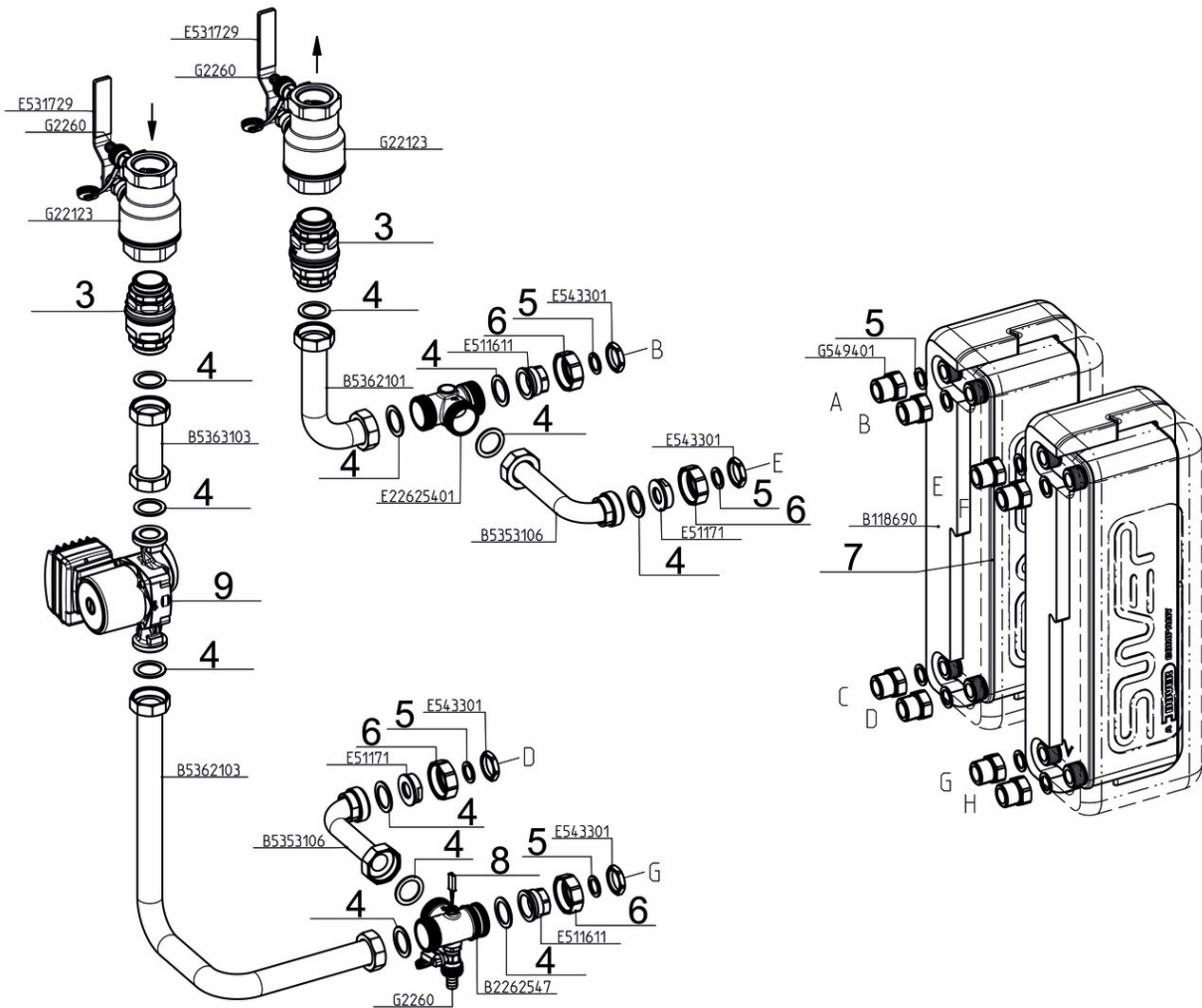

9.3 Spare parts secondary circuit

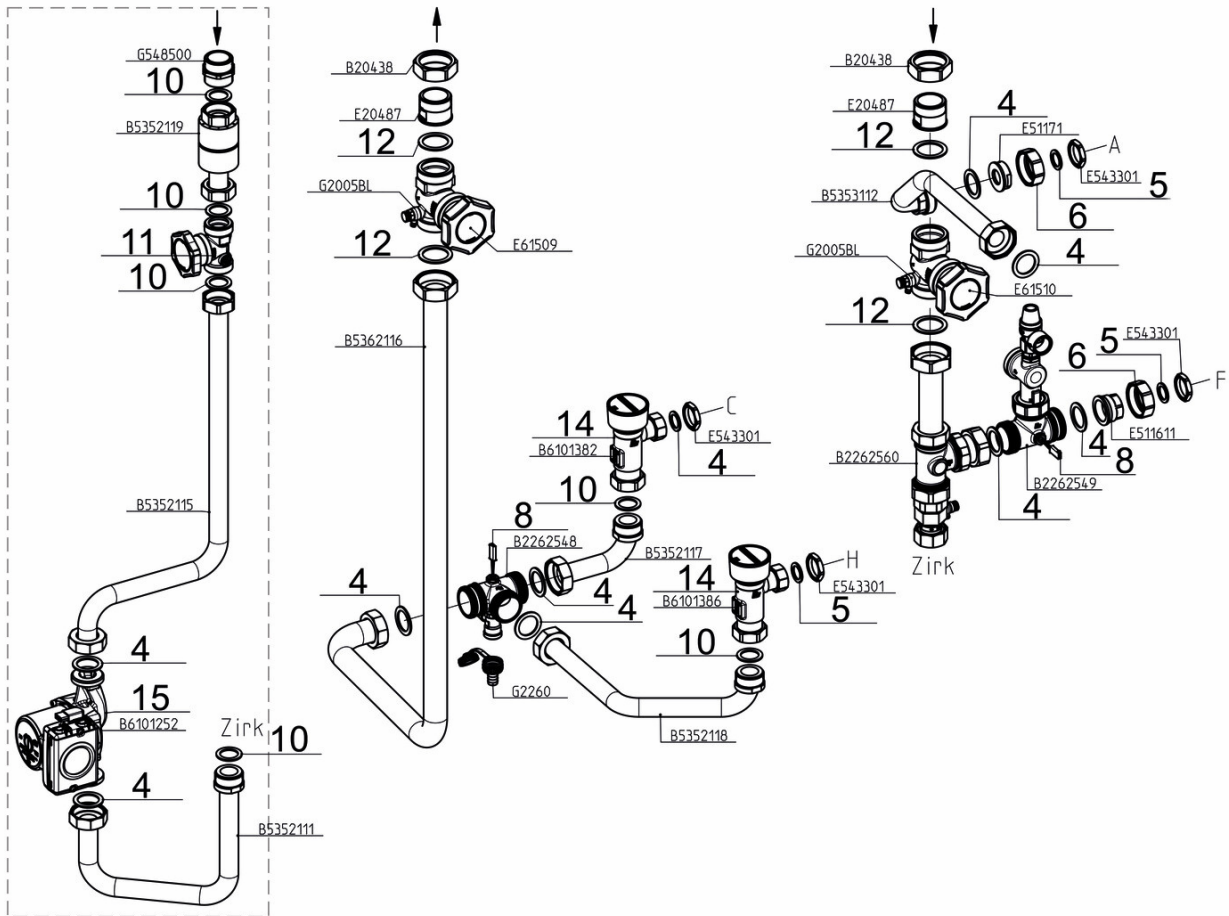

The marked hydraulic line corresponds to the version with circulation.

9 Scope of delivery [specialist]

Position	Spare part	Item no.
1	Controller FC3.10	N00597
2	EPP insert Friwa Mega with cut-out for controller	N00449
3	Check valve DN 40, 2x 1½" ext. thread, o-ring, 450 mm wc	N00368
4	Seal 44.0 x 32.0 x 2.0, 1", for thread connection 1½", AFM, 10 pieces	N00036
5	Seal 30.0 x 21.0 x 2.0, ½", for thread connection 1", AFM, 10 pieces	N00024
6	Union nut G 1½", passage 42 mm, wrench size 52, octagonal	N00269
7	Heat exchanger, copper solder, with seals, for station 6407511, 6407517	N00601
	Heat exchanger, coated, with seals, for station 6407530, 6407535	N00281
8	Temperature sensor Pt1000, screw-in sensor 15 mm, G¼", with connection line	N00360
9	Grundfos UPMXL 25-125, 1½" ext. thread, 180 mm, with seals	N00367
10	Seal 38.0 x 27.0 x 2.0, ¾", for thread connection 1¼", AFM, 10 pieces	N00174
11	Piston valve DN 25, 2x 1¼" ext. thread, with seals	N00574
12	Seal 50.0 x 38.0 x 2.0, 1½", for thread connection 1¾", AFM, 10 pieces	N00187
13	Pressure relief valve ½" x ¾", MSV 10 bar	N00008
14	Flow Sonic DN 25, 1" union nut x 1¼" union nut, with Pt1000, with seals and sensor cable	N00277
15	Circulation pump Grundfos UPML 25-105 N, 1½" ext. thread, with seals, for station 6407517, 6407535	N00357

10 Technical data

Station	FriwaMega
Dimensions	
Height (with insulation)	1402 mm + adjustment of the stand feet approx. 15 mm
Height (with circulation set)	1500 mm + adjustment of the stand feet approx. 15 mm
Width (with insulation)	710 mm
Depth (with insulation)	920 mm
Centre distance primary circuit	158 mm
Centre distance secondary circuit	158 mm
Pipe connections	
Primary circuit (storage tank circuit)	1½" int. thread
Secondary circuit (DHW circuit)	1¾" ext. thread, flat sealing
Operating data	
Max. admissible pressure	primary: 3 bar, secondary: 10 bar
Operating temperature	2 – 95 °C
Equipment	
Check valve	primary: 2 x 450 mm wc, can be opened
Primary pump	High-efficiency pump with PWM control, 3-180 W
Secondary pump 6407517 / 6407535	(optional) High-efficiency pump with PWM control, 6-140 W
Heat exchanger	2 x 60 plates
Flow rate sensor	secondary: 2 x FlowSonic, measuring range: 1-130 l/min
Temperature sensor	3 x Pt1000, rapid
Materials	
Valves and fittings	Brass
Seals: o-rings	EPDM
Flat seals	EPDM / AFM 34
Plate heat exchanger	uncoated: stainless steel 1.4401 / solder: 99.99% Cu coated: SiO ₂
Insulation	EPP
Check valve	Brass

10.1 Pressure drop and pump characteristic curves

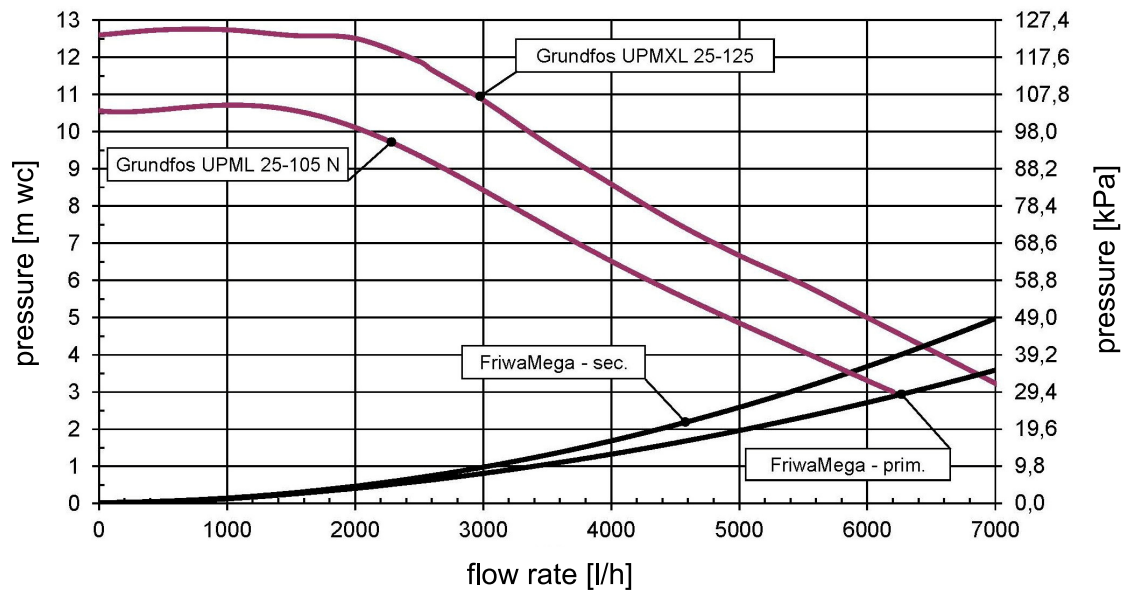

10.2 Dimensional drawing

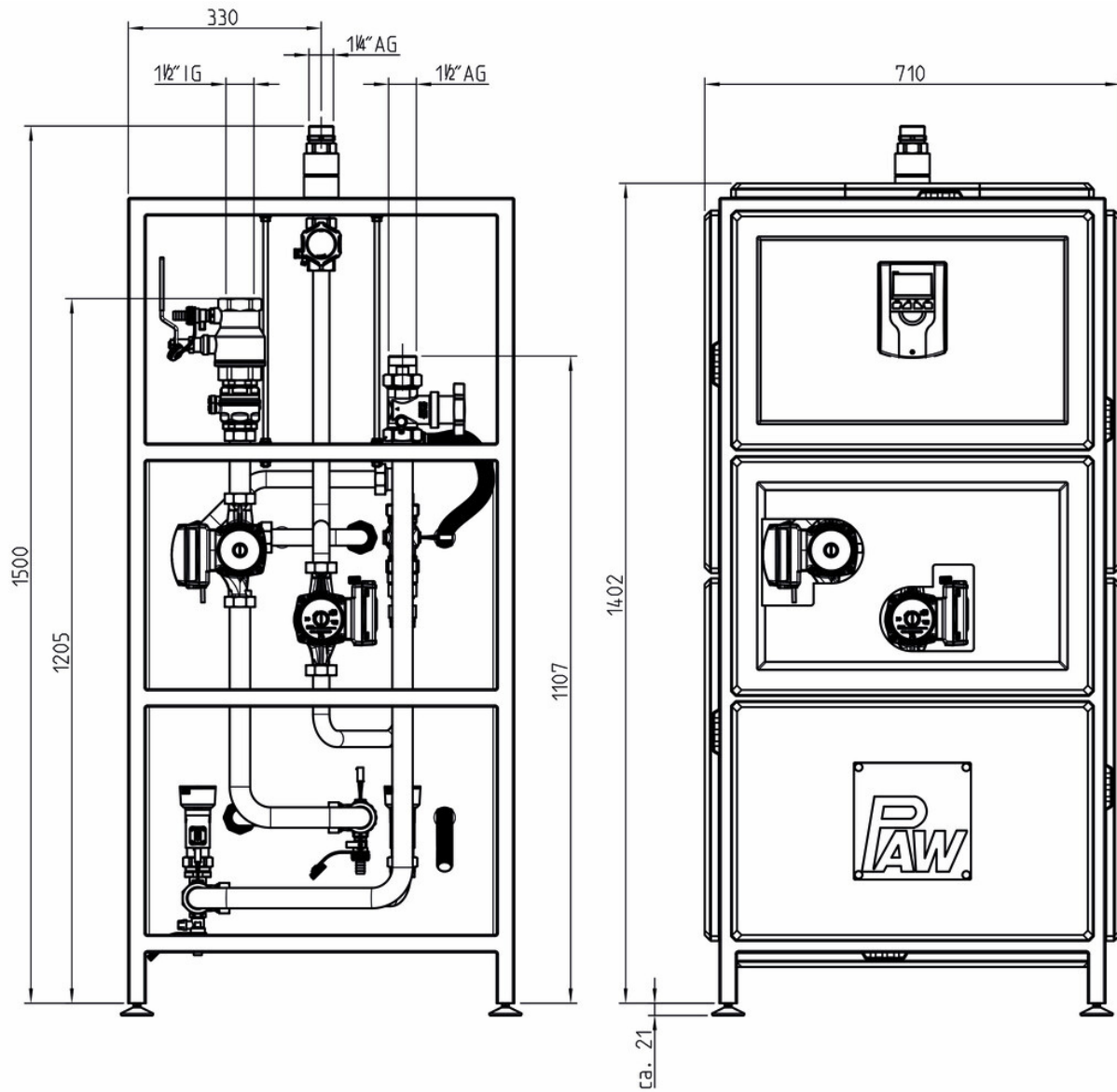

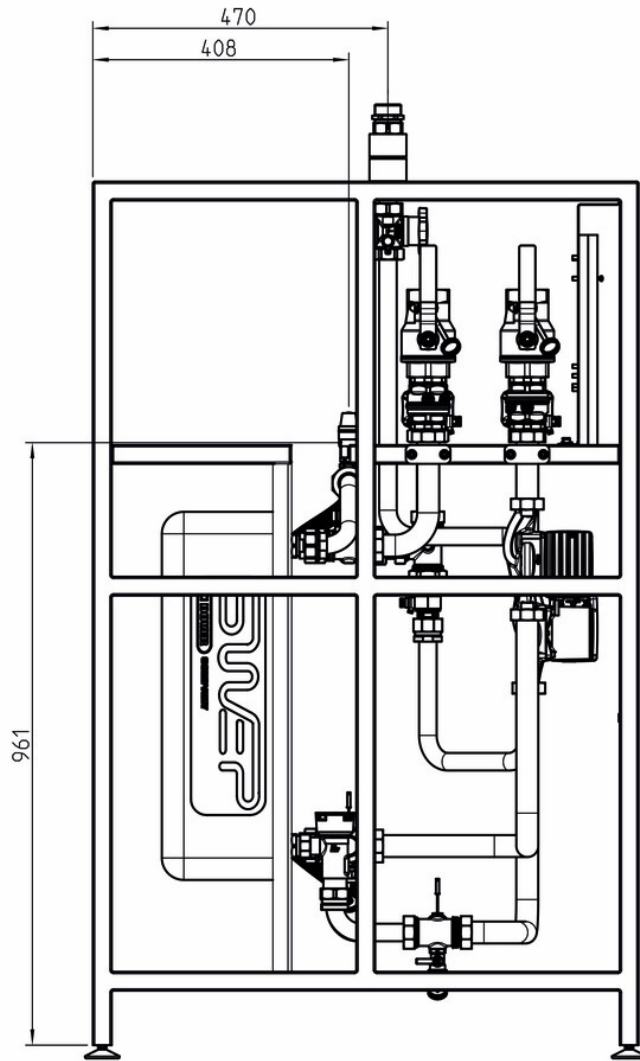

11 Disposal

NOTICE

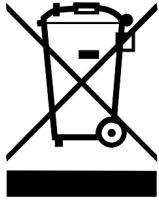

Electrical and electronic devices must not be disposed of in the household waste. For your return, there are free collection points for electrical appliances and, if necessary, additional points of acceptance for the reuse of the devices in your area. The addresses can be obtained from your city or communal administration.

If the old electrical or electronic device contains personal data, you are responsible for deleting it before returning the device.

Batteries and rechargeable batteries must be removed prior to the disposal of the product. Depending on the product equipment (partly with optional accessories), single components can also contain batteries and rechargeable batteries. Please observe the disposal symbols on the components.

NOTICE



Disposal of transport and packaging materials

The packaging materials are made of recyclable materials and can be disposed of with recyclable materials.

12 Commissioning report

System operator	
Location of installation	
Serial numbers:	
<ul style="list-style-type: none"> • Domestic hot water module 	
<ul style="list-style-type: none"> • Flow rate sensor 	
<ul style="list-style-type: none"> • Controller 	
<ul style="list-style-type: none"> • Software version 	
Pipes primary	diameter = mm; length = m
Pipes secondary	diameter = mm; length = m
Pipes circulation	diameter = mm; length = m
Other additionally installed components	<input type="checkbox"/> return distribution set
	<input type="checkbox"/> other
Have both circuits been flushed and vented correctly? (no air noises in the pump)	<input type="checkbox"/> vented
Are all shut-off valves open in the cold water line?	<input type="checkbox"/> open
Is there a pressure of at least 1.5 bar on the primary side?	<input type="checkbox"/> checked
Is there a pressure of at least 2.5 bar on the secondary side?	<input type="checkbox"/> checked
Is the potential equalisation processed according to regulations?	<input type="checkbox"/> checked
Is there an error message on the display?	<input type="checkbox"/> no message
Installation company	Date, signature

Item no. 9964075x-mub-en

Translation of the original instructions

We reserve the right to make technical changes without notice!

Printed in Germany – Copyright by PAW GmbH & Co. KG

PAW GmbH & Co. KG

Böcklerstraße 11

31789 Hameln, Germany

www.paw.eu

Phone: +49-5151-9856-0

Fax: +49-5151-9856-98