



Modular heating circuit K34 - DN 32 with 3-way mixing valve and bypass 0-50 %

• for mixed low-temperature heating

Flat-sealing connections 2" external thread
incl. 2" union nut for the installation on a PAW modular distribution manifold. With PAW mounting equipment the heating circuit can be installed on wall brackets.

3-way mixing valve with adjustable bypass completely made of brass, linear characteristic (prevents temperature variation). Through the adjustable bypass on the front of the mixing valve 0 to 50 % of return water are mixed with the flow water, depending on the heating system. For mounting actuators of other manufacturers, you need the adapter set item no. 705580.

PAW actuator SR5 with 1.5 m cable and mounting set for snap-in assembly on the mixing valve, suited for flow on the right or left side, change-over switch for manual / automatic operation, supply 230 V / 50 Hz, torque 5 Nm.

Pumps fitted with 2 m cable, pre-installed, ALPHA pump with right-angle plug, completely preassembled, integrated in the insulation, pressure tested, with serial number.

Check valve integrated into the mixing valve, prevents unwanted circulations.

Flow and return line can be changed on site, the mixing valve can be easily adapted. The heating circuits can be delivered with flow on the left against additional charge.



TECHNICAL DATA K34 - DN 32

Materials

Valves and fittings	Brass
Gaskets	EPDM / NBR
Insulation	EPP

Technical data

Nominal pressure	6 bar
Max. operating temperature	110 °C
Kvs value	10.8

Dimensions

Connection generator	2" ext. thread, flat sealing
Connection consumer	1 1/4" internal thread
Centre distance	125 mm
Installation length	385 mm
Width	250 mm
Height	448 mm

Recommended range of application, max.

Temperature difference 20 K	up to 2760 l/h	up to 64 kW
-----------------------------	----------------	-------------

Differential pressure diagram K34

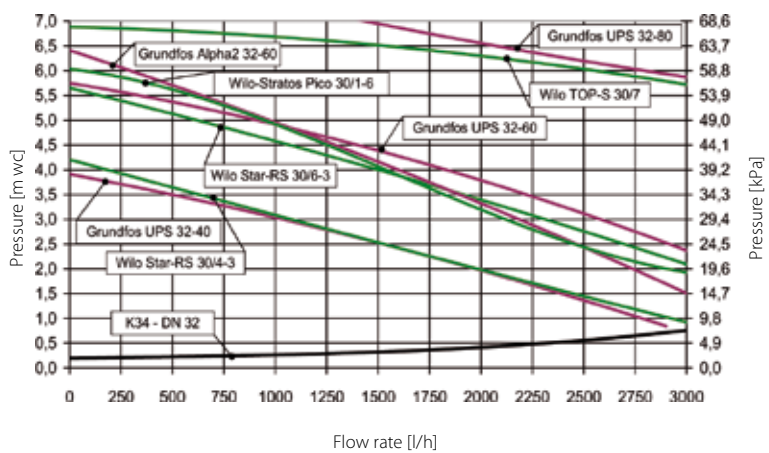

DN 32

Illustration	Actuator	K34 - DN 32	Energy	Item no.	
	SR5 	Wilo-Stratos PICO 30/1- 6 , high-efficiency pump	A	39062MWH6	
		Wilo TOP-S 30/7 , 3-speed	D	39062MWI7	
		Wilo Star-RS 30/6 , 3-speed	B	39062MWI6	
		Wilo Star-RS 30/4 , 3-speed	B	39062MWI4	
		Grundfos ALPHA2 32-60 , high-efficiency pump	A	39062MGH6	
		Grundfos UPS 32-80 , 3-speed	D	39062MGR8	
		Grundfos UPS 32-60 , 3-speed	C	39062MGR6	
		Grundfos UPS 32-40 , 3-speed	B	39062MGR4	
		for pumps with 2" external thread x 180 mm			39062M
		Wilo-Stratos PICO 30/1- 6 , high-efficiency pump		A	39062WH6
	Wilo TOP-S 30/7 , 3-speed		D	39062WI7	
	Wilo Star-RS 30/6 , 3-speed		B	39062WI6	
	Wilo Star-RS 30/4 , 3-speed		B	39062WI4	
	Grundfos ALPHA2 32-60 , high-efficiency pump		A	39062GH6	
	Grundfos UPS 32-80 , 3-speed		D	39062GR8	
	Grundfos UPS 32-60 , 3-speed		C	39062GR6	
	Grundfos UPS 32-40 , 3-speed		B	39062GR4	
	for pumps with 2" external thread x 180 mm			39062	
	Extra charge for assembly with flow on the left per heating circuit			999300	

Mounting equipment K34 - DN 32

Overflow set DN 25/DN 32

2854

see page 90

Wall bracket set DN 32

3722SET

see page 91

Flush and drain set DN 32

3761

see page 91

Connection set DN 32

3731

see page 91

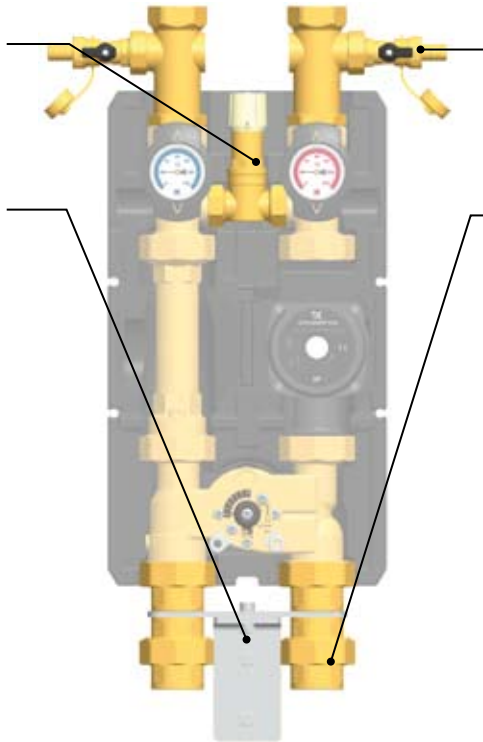

Fitting for heat flowmeter (mixed heating circuits) DN 32

433746

see page 90

Coupling piece for overhead installation DN 32

3724

see page 91

Mounting plate

3725

see page 91

Immersion sleeve 1/2" ext. thread

566001 5.5 mm x 30 mm

5660021 6 mm x 60 mm

see page 90

PAW actuator SR 5

705001

see page 92

Distribution manifold DN 32

3712 2-fold

3713 3-fold

3714 4-fold

3715 5-fold

3716 6-fold

see page 86

Wall bracket DN 32

3721

see page 91

